

Max. Gross Weight	34,000 KG	74,960 LBS
Container Weight (Reefer Unit)	4,060 (380) KG	8,950 (838) LBS
Max. Payload	29,560 KG	65,170 LBS
Cubic Capacity	68.7 m <sup>3</sup>	2,430 ft <sup>3</sup>
Floor Area	26.5 m <sup>2</sup>	285 ft <sup>2</sup>
Insulation Density	40 - 55 kg/m <sup>3</sup>	2.5 - 3.4 lb/ft <sup>3</sup>
Floor Strength	7,260 KG	16,000 LBS

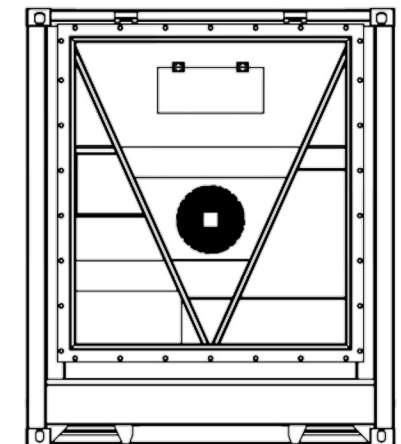
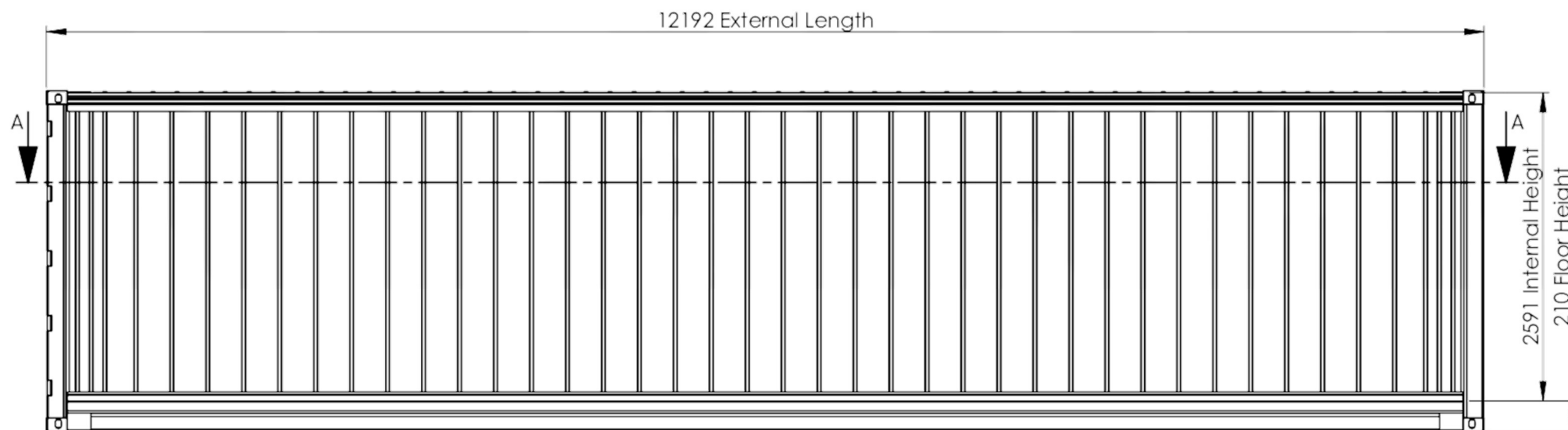
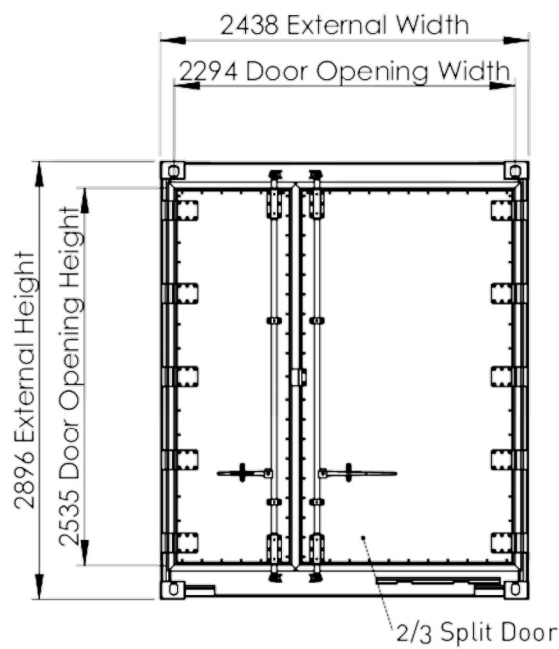
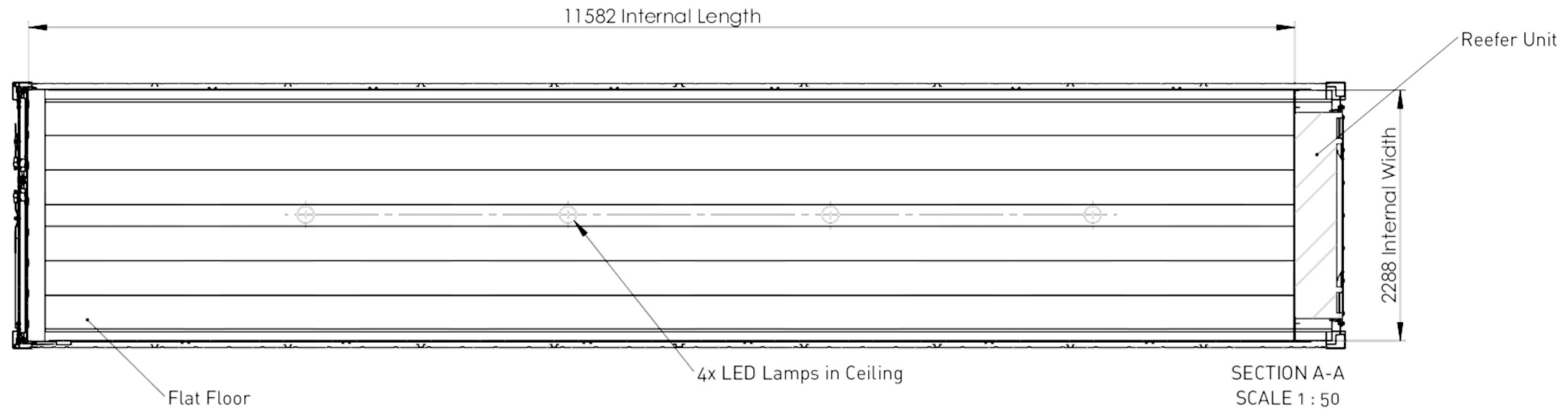

	NAME	SIGNATURE	DATE
DRAWN	JM		29/01/2019
APPVD			

Preliminary Drawing for Information Only	
REVISION:	DO NOT SCALE DRAWING
PROJECT:	Thermaright Containers Standard Containers
DESCRIPTION:	40' Refrigerated Container High Cube 2/3 Split Doors
	A3
©2019 Thermaright	SCALE: 1:50 (UNLESS STATED OTHERWISE) SHEET 1 OF 1