

## OPERATING SPECIFICATIONS

### WORKING DIMENSIONS

Maximum Working Height .....	4.50m
Maximum Platform Height .....	2.50m
Outreach with cantilever deck to cage edge .....	0.50m
Basket Dimensions .....	1.00 x 0.73m
Basket Dimensions with cantilever .....	1.50 x 0.73m
Working Footprint .....	1.19 x 0.75m
Safe Working Load .....	200kg (1 person + tools)
No. Persons .....	1
Maximum Manual Force .....	200n
Maximum Gradient for Operation .....	0°
Maximum Wind Force .....	12.5 m/s
Maximum weight inc payload .....	678kg
Drive Speed Max .....	4.6KpH
Drive Speed Slow .....	1.0KpH
Maximum Castor Point Load .....	210kg (2.10 kN)

### CLOSED DIMENSIONS

Length .....	1.20m
Width .....	0.75m
Height .....	1.59m
Weight .....	478kg

### POWER SOURCE

Standard 24V DC Electric Motor  
24V D.C. Motor / Gearbox Drive

### BATTERY CHARGER SPECIFICATION

Input Voltage .....	90-265v A.C.
Frequency .....	45-65 Hz
Output .....	24V DC, 7A

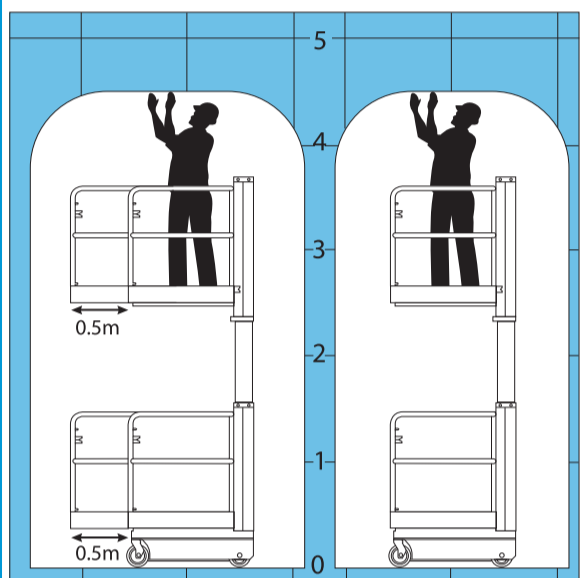

## EQUIPMENT CARE

**Never push the equipment beyond its design limits.** If it will not do what you want with reasonable ease and speed, assume you have the wrong equipment for the job. Contact Thermaright for advice.

**Keep the equipment clean** - you will find this less of a chore if you clean it regularly, rather than wait until the end of the hire period.

**When not in use, store the equipment somewhere clean, dry and safe from thieves.**

## FINISHING OFF

**Lower the cage and exit. Turn the unit off and as a safety precaution, press red STOP button. Collect all parts together and give them a final clean up ready for return, to Thermaright.**



**Thermaright**  
Hire Solutions

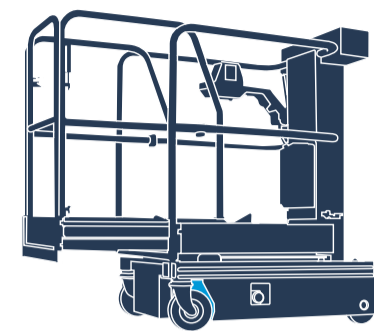

# Self Propelled Low Level Platform

Ideal for working on raised access flooring or other delicate flooring due to its low overall weight and low point loading.

### ... have you been trained

The law requires that personnel using work equipment have received adequate training and must be competent when using the equipment within the workplace.

### ...any comments?

If you have any suggestions to enable us to improve the information within this guide please e-mail your comments or write to the Safety Guide Manager at the address below e-mail: [info@thermaright.co.uk](mailto:info@thermaright.co.uk)

Thermaright Hire Solutions LTD  
Unit 2, Modular Court, Enterprise Drive,  
Wolverhampton, WV10 7DF  
[www.thermaright.co.uk](http://www.thermaright.co.uk)



Code 69914

## IDENTIFIER

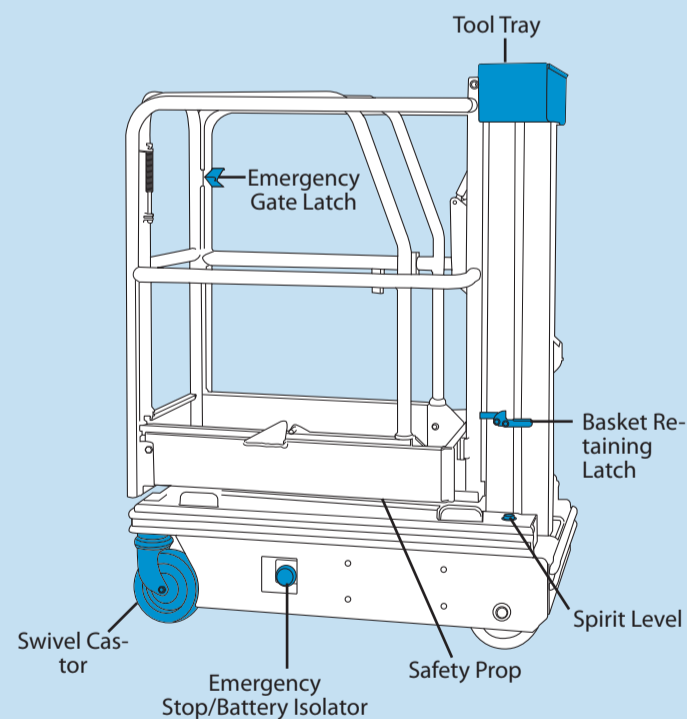
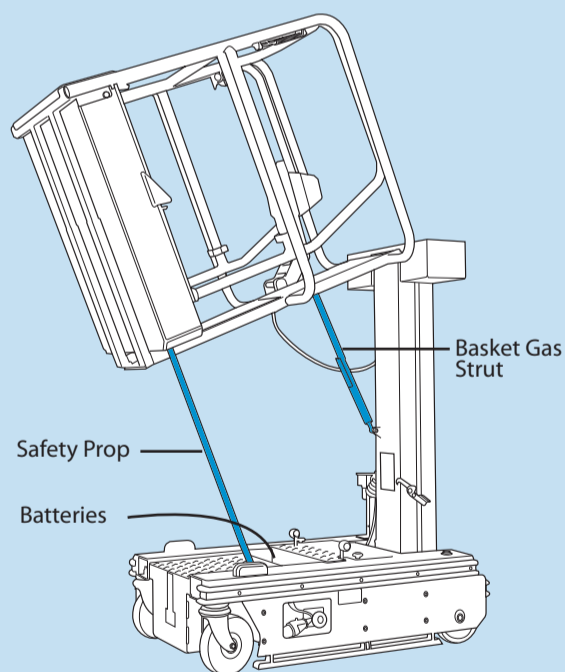
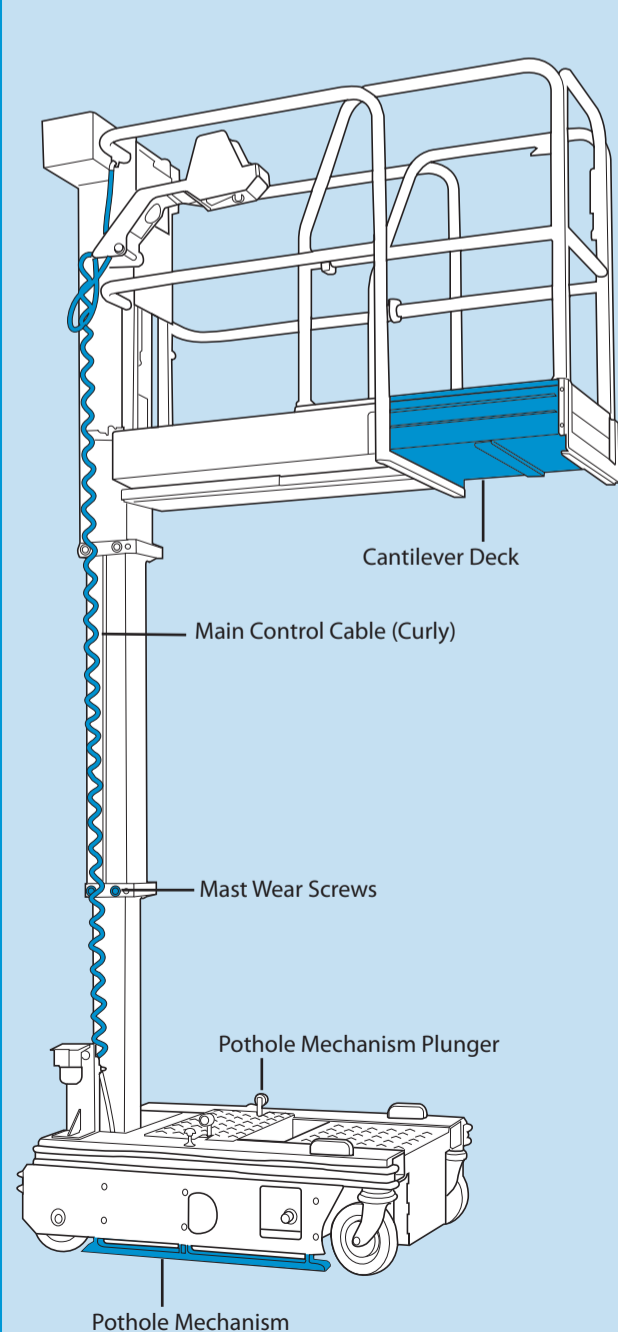

### CONTROL ARM

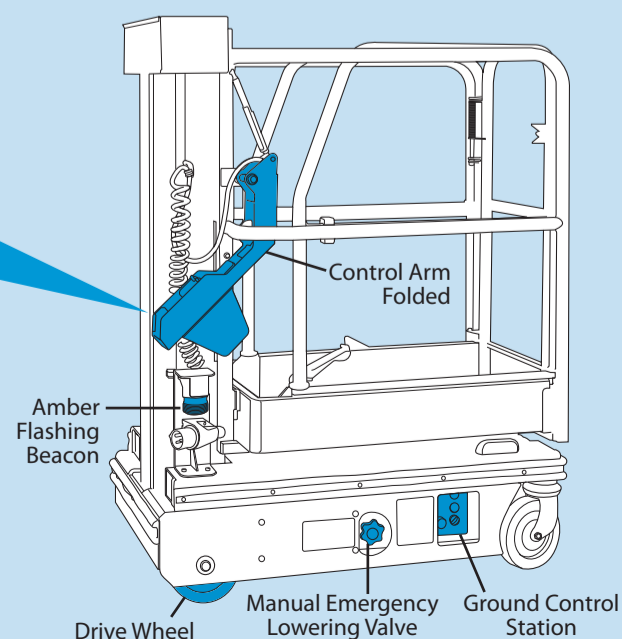
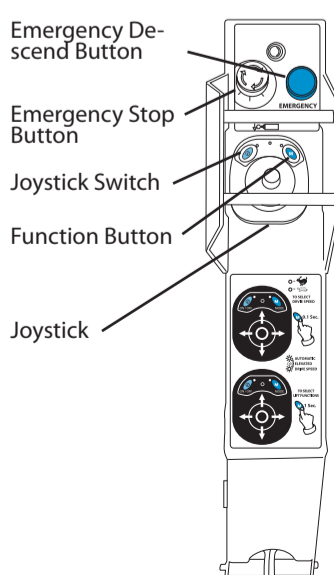

## GENERAL SAFETY

For advice on the safety and suitability of this equipment contact Thermaright.

There is a serious risk of personal injury if you do not follow all instructions laid down in this guide.

The hirer has a responsibility to ensure that all necessary risk assessments have been completed prior to the use of this equipment.

This equipment should only be used by an operator who has been deemed competent to do so by his/her employer.

This equipment should be used by an able bodied, competent adult who has read and understood these instructions. Anyone with either a temporary or permanent disability, should seek expert advice before using it.

Keep children, animals and bystanders away from the work area. Cordon off a NO GO area using cones and either barriers or tape, available for hire from Thermaright.

 **Never use** this equipment if you are ill, feeling tired, or under the influence of alcohol or drugs.

 **Wear practical, protective clothing, gloves, footwear and a protective hard hat.** Avoid loose garments and jewellery that could catch in moving parts, tie back long hair.

**Do not work near flammable gases or liquids, petrol or paint thinner fumes for example. Keep combustible materials at a safe distance – at least 5m.**

Make sure you know how to switch this equipment OFF before you switch it ON in case you get into difficulty.

Make sure you know how to operate this equipment safely and are aware of its limitations before you use it.

Make sure that everyone is warned of what you are doing.

If working in areas where wind gusts occur, **DO NOT USE THE MACHINE.**

The maximum number of occupants must not exceed one.

Use only on hard, level surfaces able to support the weight of the machine (e.g. concrete floor, tiled floor, hard wood floor).

Never use the lift near overhead power lines or similar hazards.

Never exceed the equipment's safe working load of 200kg (including person).

Never operate the equipment alone. Ensure a competent adult is always within shouting range to operate the manual descent system or come to your aid if anything should go wrong.

Never use the Power Tower as a goods lift or crane.

Never try to move the Power Tower on its castors when elevated.

Never extend the height of the platform by using boxes, steps ladders etc.

Never drive machine near holes in the floor (or edge of concrete slab, manholes, drains etc.).

The ideal position to operate the tower is to stand facing towards the gate end with your back against the mast (see image in Operating Specifications).

Switch on joystick controller by depressing the green on/off button - left.

Select function by pressing blue mode button. Press and immediately release (0.1 second approximately) to select drive speed right hand LED will illuminate (Green = fast; Orange = slow). Press and hold for approximately 1 second to select lift functions centre LED light will illuminate.

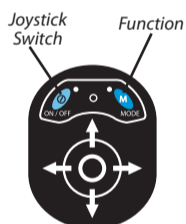

When drive is selected move joystick forward, backward, left and right as required. Drive speed is infinitely variable depending on how far the joystick is moved. To stop the tower release the joystick. Take particular care when driving in fast speed when cantilever deck is extended, quick turns may be awkward to control in confined areas.

Always select slow speed when driving in congested / confined areas.

When lift function is selected, move joystick forward (towards gate) to elevate, backwards to descend. Always check for overhead obstructions before elevating.

### EMERGENCY OPERATION

This machine is fitted with two modes of emergency lowering, one from the basket and one at the ground.

#### From the basket:

In the event of the tilt alarm cut out or overload cut out being activated the basket control joystick will be immobilised and a red light on the basket control panel will illuminate. To descend, press the black button A on the basket control panel. Releasing the button will stop the descent.

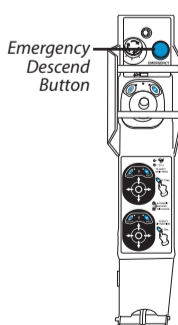

In the event of basket joystick control malfunction, the same emergency lowering procedure as described above can be followed.

#### From the ground:

In the event of control failure or operator incapacity the emergency lowering valve located on the chassis (right hand side - looking from mast, below fork truck pocket) can be used to manually lower the platform. Simply pull the emergency lowering valve B to lower the platform.

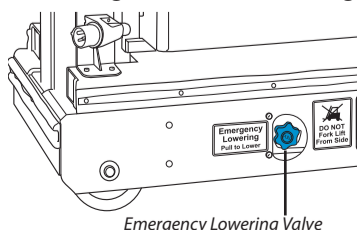

Never exceed horizontal forces (maximum horizontal force 20dN).

Ensure that the safe working load is evenly distributed in the basket.

Never modify the Power Tower in any way without the full approval of the manufacturer.

Never attempt to enter or exit the platform unless it is fully lowered.

Only use this equipment on firm, level ground capable of supporting its weight. DO NOT use it on slopes, soft ground or where there is a risk of subsidence.

Check the equipment's condition before use and at regular intervals thereafter. If it shows signs of damage or excessive wear, DO NOT USE IT. Return it Thermaright.

For additional information please refer to the manufacturer's operator's manual.

## PRE-OPERATION INSPECTION

It is the responsibility of the operator to perform a pre-operation inspection.

The pre-operation inspection is a visual inspection performed by the operator prior to each work shift. The inspection must be performed before use of Power Tower (see Pre-operation Checklist).

## ELECTRICAL SAFETY

### FIRE WARNING

Batteries generate highly flammable and potentially EXPLOSIVE hydrogen gas when charging, so, until charging is over and the gas has dispersed...

ALWAYS stand the lift in a well-ventilated spot, preferably in the open air.

ALWAYS open the battery compartment cover.

NEVER smoke or allow naked lights and other ignition sources into the area.

This equipment is powered by 24V DC batteries.

Always fully charge before use and recharge at regular intervals.

Never operate the lift when charging the battery.

After charging, switch OFF the power supply and disconnect the power supply lead from the charger. If the charger fails, or its power supply cable or lead becomes damaged, return the unit. Do not attempt to repair anything yourself.

Keep the charger dry at all times. Using electrical equipment in wet or damp conditions can be dangerous.

To reduce the risk of electric shock, always use a suitable RCD (Residual Current-Operated Device) available from

 Thermaright.

Stand clear of the descending structure. Release emergency valve to stop descent.

### BATTERY CHARGING

The battery charger is located under the checkerplate cover.

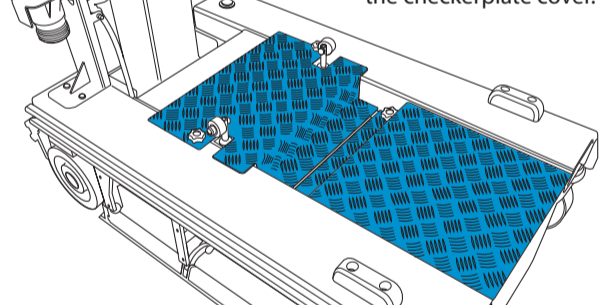

First switch off machine and isolate power by depressing the battery isolator switch at base of machine.

The charging lead (usually fitted with a yellow 110V plug) is on the exterior of the machine base (this lead can be fitted with 230V plug if required). The battery charger is fully voltage sensitive, so there is no voltage selection to do when connecting to different voltages.

Plug into an available power supply and ensure the Green LED (top of charger) illuminates. The charger LED indicator lights can be viewed through the window in the chassis (when viewed from behind the castor) adjacent to the charging lead. The Amber LED has three modes:

1. Rapid flash, which indicates maximum charge rate.
2. Slow pulse, indicating slower charging.
3. Continuous illumination indicating the battery is fully charged.
4. Additionally the battery charge indicator is the left hand LED on basket joystick.

The battery charger can be connected to the mains supply at any time or left for extended periods. The machine can be operated when the charger is connected, although this is not recommended.

All mains supply should be protected with a suitable RCD (see Electrical Safety).

## GETTING STARTED

Never use this equipment until you have fully read and understood this User Guide and the machine has been properly set up using the information it contains.

This equipment is designed to be a simple, safe and efficient self-propelled alternative to push-around platforms or traditional scaffold tower or podium steps. It can be used for many applications including construction and maintenance where the convenience and efficiency of using a self-propelled platform is preferred.

It is suitable for any application provided it is used within its specified operating parameters. If used for applications such as sand blasting, welding, paint spraying or with any other hazardous materials, measures must be taken to ensure this equipment does not become damaged in any way which may impair safety or reliability. Additional protection for the operator may be required in some cases, which is the responsibility of the operator.

It is essential to be familiar with the correct operating procedures. The operator must have adequate training for this type of Tower.

Before operating machine familiarise yourself with the work area, check for possible hazards such as potholes, ramps, slopes and overhead obstructions that could affect the safe use of the equipment.

This tower is fitted with a lanyard attachment point as standard. It is recommended that if the operator chooses to wear a safety harness, an approved 'fall restraint' type harness should be worn.

Operating procedures should be preceded with pre-operation checks (see Pre-operation checklist).

The operator must understand the machines operation process which describes the way to use the equipment safely. You must familiarise yourself with the Emergency Operation in case of power failure or in the event of operator incapacity.

## BASIC TECHNIQUES

Only use this equipment internally, on hard level surfaces. Ensure a person is available at ground level to assist in case of emergency.

### OPERATION PROCESS

Ensure all pre-operation checks have been carried out.

Check spirit level to ensure the machine is level. Then turn ignition key in ground emergency stop button and release. Power light should illuminate. Make sure 'Platform' is selected on ground control panel.

Enter basket via gate and ensure the gate is closed and latched correctly when in basket.

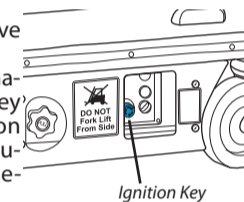

## PRE-OPERATION CHECKLIST

- Check the working area is suitable for machine
- Check the ground is capable of supporting total weight of the machine and its payload.
- The ground should be free from debris and the operator should beware of holes, hatches, pits, unprotected manholes, drains etc
- Cordon off work area
- Check there are no live electrical cables or conductors that the operator could come close to or into contact with when carrying out tasks.
- Check there are no overhead obstructions likely to cause danger
- Carry out a thorough visual inspection of the machine. Look specifically for any signs of damage (Handrails, platform deck, cantilever deck, lifting mast structure, chassis area structure, pothole mechanism).
- Check wheels, tyres, castors and fixings
- Main control cable (curly cable to control arm).
- Check all key fixings are intact and tight.
- Ensure battery is charged by checking joystick LED light (green = charged).
- Ensure hydraulic oil level is at correct level. Do not overfill. Check for hydraulic leaks.
- Check machine functions are working correctly before normal use.
- Check lift functions at ground and in basket by lifting approx. 0.5m.
- Check emergency lowering functions at ground and in basket by lifting 0.5m
- Check pothole mechanism and interlock work correctly by lifting 0.5m
- Check emergency stop functions at ground and in basket.
- Check drive and steer functions work correctly by selecting slow speed in closed position first, followed by fast speed. Check automatic elevated drive speed is engaged by elevating approx. 0.5m. Then select drive; the joystick right-hand mode light (orange or green) should be flashing and drive speed should be slightly slower than slow dosed speed. Check machine brakes when joystick is released.