

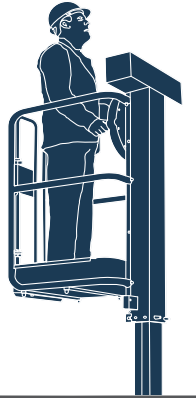

Thermaright
Hire Solutions



Peco Manual Access Platform

Non-powered access platform, that does not require batteries or connection to an electricity supply. With a platform height of 1.5mtr



Code 69916

PRE-OPERATION CHECKLIST

1. Visually inspect the lift for any signs of damage to handrails, platform tray, chassis and mast lifting structure including mast fixing bolts.
2. Check castors and wheels rotate freely and are undamaged.
3. Check castor wheel and castor fixings.
4. Check that the front rubber chassis feet (pads) are undamaged and fixings are secure
5. Check spirit level is intact and bubble is centred to ensure machine is level.
6. Check gates, gate hinges, hinge springs and hinge fixings are undamaged and that gates open and close correctly
7. Step into basket; check machine sinks down to rest on front rubber pads (feet).
8. When standing in the basket check 'fly-wheel' operating handle works correctly. Hold handle firmly and pull operating knob towards you, release, knob should spring back to lock wheel. Repeat but turn handle once clockwise with knob held pulled towards you. Wheel should turn freely. Turn once anti-clockwise to come down.
9. Check emergency lowering tool is attached on the chassis.

OPERATING SPECIFICATIONS

WORKING DIMENSIONS

Maximum Working Height	3.50m
Maximum Platform Height	1.50m
Platform Dimensions.....	720mm x 600mm
Working Footprint.....	985mm x 0.700m
Safe Working Load.....	150kg(1 person + tools)
No. Persons	1
Maximum Manual Force.....	200n
Maximum Gradient for Operation.....	0°
Maximum Wind Force	0mph (INDOOR ONLY)
Maximum Wheel Force	125kg
Maximum Castor Point Load	125kg (123kN)
Sound Pressure Level	Less than 70 dBA

CLOSED DIMENSIONS

Length.....	985 mm
Weight.....	700 mm
Height	1.550 m
Weight.....	180 kg

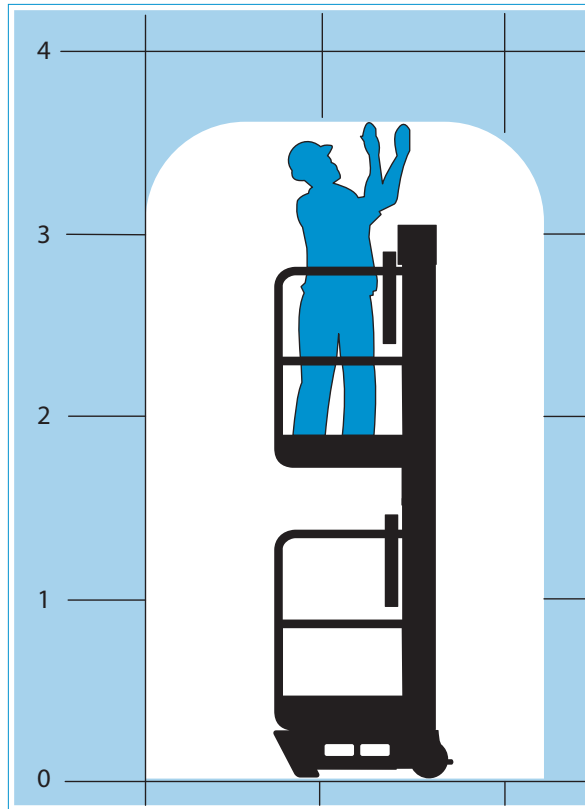

EQUIPMENT CARE

Note: The telescopic mast is a sealed unit which contains a pressurised cylinder. **Never try to dismantle it.**

The most important regular maintenance to be carried out by the operator is visual inspection, as per the pre-operation checks.

Never push the equipment beyond its design limits. If it will not do what you want with reasonable ease and speed, assume you have the wrong equipment for the job. Contact Thermaright for advice.

Keep the equipment clean - you will find this less of a chore if you clean it regularly, rather than wait until the end of the hire period.

When not in use, store the equipment somewhere clean, dry and secure.

FINISHING OFF

Lower the cage and exit.

Give the Peco a final clean up ready for return, to Thermaright.

... have you been trained

The law requires that personnel using work equipment have received adequate training and must be competent when using the equipment within the workplace.

...any comments?

If you have any suggestions to enable us to improve the information within this guide please e-mail your comments or write to the Safety Guide Manager at the address below
e-mail: info@thermaright.co.uk

Thermaright Hire Solutions LTD
Unit 2, Modular Court, Enterprise Drive,
Wolverhampton, WV10 7DF
www.thermaright.co.uk

GENERAL SAFETY

For advice on the safety and suitability of this equipment contact Thermaright.

There is a serious risk of personal injury if you do not follow all instructions laid down in this guide.

The hirer has a responsibility to ensure that all necessary risk assessments have been completed prior to the use of this equipment.

This equipment should only be used by an operator who has been deemed competent to do so by his/her employer.

This equipment should be used by a competent adult who has read and understood these instructions. Anyone with either a temporary or permanent disability, should seek expert advice before using it.

Keep children, animals and bystanders away from the work area. Cordon off a NO GO area using cones and either barriers or tape, available for hire from Thermaright.

 **Never use** this equipment if you are ill, feeling tired, or under the influence of alcohol or drugs.

 **Wear practical, protective clothing, gloves and footwear.** Avoid loose garments and jewellery that could catch in moving parts, tie back long hair.

Do not work near flammable gases or liquids, petrol or paint thinner fumes for example. Keep combustible materials at a safe distance – at least 5m.

Make sure **you know how to operate this equipment** safely and are **aware of its limitations** before you use it.

Make sure that everyone is warned of what you are doing.

This machine is designed **for internal use ONLY**. If working in a building which has large openings where wind gusts occur, **do NOT use it**.

The maximum number of occupants must not exceed one.

Never use the lift near overhead power lines or similar hazards.

Never exceed the equipment's safe working load of 150Kg. Ensure safe working load is evenly distributed on the platform.

Never operate the equipment alone. Ensure a competent adult is always within shouting range to operate the manual descent system or come to your aid if anything should go wrong.

Never try to move the tower on its castors when elevated.

Never extend the height of the platform by using boxes, steps ladders etc.

Never modify the machine in any way without the full approval of the manufacturer.

Never attempt to enter or exit the platform unless it is fully lowered.

Only use this equipment on firm, level ground capable of supporting its weight. Do not use it on slopes, soft ground or where there is a risk of

IDENTIFIER

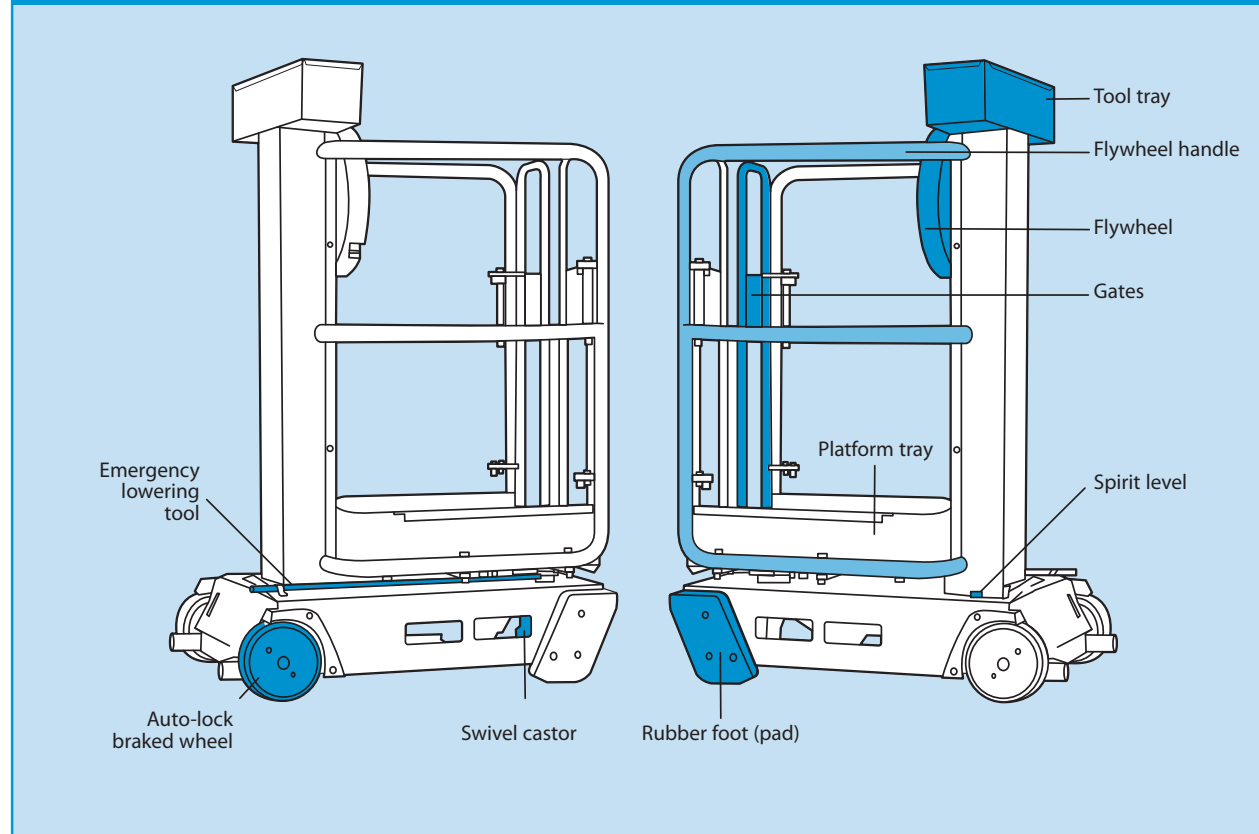

subsidence.

Ensure guardrail gates are closed before elevation.

Ensure that operator is fit and does not suffer from the fear of heights.

Never exceed horizontal forces (max horizontal force 200N).

Check the equipment's condition before use and at regular intervals thereafter. If it shows signs of damage or excessive wear, do not use it. Return it to Thermaright.

For additional information refer to the manufacturer's operator's manual.

PRE-OPERATION CHECKLIST

It is the responsibility of the operator to perform a pre-operation inspection.

The pre-operation inspection is a visual inspection performed by the operator prior to each work shift.

The inspection must be performed before the use of this equipment (see Pre-operation Checklist).

GETTING STARTED

The Peco Manual Access Platform is designed for working internally on flat level surfaces. Ideally suited to working in a very wide range of applications from the very clean environments from hospitals, food and drinks production facilities, pharmaceutical and retail, to facilities maintenance, shop fitting and construction.

Never use the Peco Manual Access Platform until you have fully read and understood this User Guide and the machine has been properly set up using the information it contains.

It is suitable for any application provided it is used within its specified operating parameters. If used for applications such as sand blasting, welding, paint spraying or with any other hazardous materials, measures must be taken to ensure this equipment does not become damaged in any way which may impair safety or reliability. Additional protection for the operator may be required in some cases, which is the responsibility of the operator.

It is essential to be familiar with the correct operating procedures. The operator must have adequate training for this type of Tower.

Before operating the unit familiarise yourself with the work area, check for possible hazards such as potholes, ramps, slopes and overhead obstructions that could affect the safe use of the equipment.

The Peco platform can be fitted with the safety harness point. If the operator chooses to wear safety harness, an approved 'fall restraint' type harness should be worn with a very short lanyard.

WARNING!

Only use the Peco platform internally, on hard level surfaces. Ensure a person is available at ground level to assist in case of emergency.

Operating procedures should be preceded with pre-operation checks (see Pre-operation checklist).

The operator must understand the machines operation process which describes the way to use the equipment safely. You must familiarise yourself with the Emergency Operation in case of machine failure or in the event of operator incapacity.

BASIC OPERATION TECHNIQUES

OPERATION PROCESS

Ensure all pre-operation checks have been carried out.

Check spirit level to ensure the machine is level. Step into platform through gates, ensure gates close behind you and check machine is sitting on its rubber pads (feet). **Do not elevate if machine is not sitting on its rubber pads. Check there are no overhead obstructions.**

To elevate, pull operating knob towards you and turn clockwise. In order to stop, stop turning the handle and release handle knob to lock.

To descend repeat but turn handle anti-clockwise.

EMERGENCY LOWERING OPERATION

DANGER!

Never attempt to recover the machine/operator if there is any possibility the machine is contacting any live wiring/cabling and is therefore potentially 'live'.

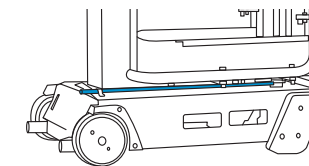

To lower the platform in the event of the operator being incapacitated (unable to operate the flywheel handle in the basket) locate emergency lowering tool on chassis.

Stand to side of machine, attach 'hook' end of emergency lowering tool to flywheel handle knob in basket, releasing handle knob, turn wheel anti-clockwise to bring platform down

